

User Manual Ceiling Hoist

AR-200



October 2022, version 2.6

© 2022, Patient Lifting Solutions

All rights reserved.

No part of this publication may be reproduced, stored in a computer data file and/or made public in any form or in any manner, whether this is electronic, mechanical, through photocopying, recording or in any other way without the prior written permission of the publisher.

Contents

1. Introduction	4
1.1. Purpose	4
1.2. Target audience	5
1.3. Symbols used	5
1.4. Safety	5
1.5. Package contents	Fout! Bladwijzer niet gedefinieerd.
1.6. Setting up	6
1.7. Correct and incorrect use	7
1.8. Cautions and warnings	7
2. Functional overview and description	9
2.1. Operation	10
2.1.1. <i>Functional overview buttons</i>	10
2.1.2. <i>Connecting the Hand Control</i>	11
2.1.3. <i>Placing the Hand Control</i>	11
2.2. Charging	12
2.3. Control lights	13
2.3.1. <i>Green ring</i>	13
2.3.2. <i>Orange ring</i>	13
2.3.3. <i>Red ring</i>	13
2.4. Safety system	14
2.4.1. <i>Battery monitoring (light and sound signals)</i>	14
2.4.2. <i>Height limit switch</i>	14
2.4.3. <i>Emergency stop</i>	15
2.4.4. <i>Belt tension</i>	15
2.4.5. <i>Belt switch</i>	15
2.5. Mechanically or electrically adjustable 4-point Spreader Bar	16
3. PLS Spreader Bar	17
3.1. Safe Working Load table	17
3.2. Important	17
3.3. Explanatory label overview	18
3.4. Connect and release	18
3.5. Attaching the Sling	19

4. Lifting a care recipient	21
5. Detachable version	23
6. PLS Rail System (optional)	24
6.1. Turntable	24
6.2. Track-Switch	24
6.3. Transit Coupling	25
7. Maintenance	26
7.1. Lifespan	26
7.2. Schedule	26
7.3. Daily maintenance	27
7.4. Weekly maintenance	27
7.5. Annual inspection and maintenance	27
7.6. Removing parts	28
7.7. If the Ceiling Hoist is not working	28
8. Appendix	29
8.1. Warranty Provisions	29
8.2. About Patient Lifting Solutions	30
8.3. Contact details Patient Lifting Solutions	30
8.4. Explanatory label overview	31
8.5. Technical specifications	32
8.6. EC Declaration of conformity	33

1. Introduction

This is the user manual for the AR-200 Ceiling Hoist, hereinafter referred to as 'AR-200' or 'Ceiling Hoist', in combination with the PLS Rail System.

We at PLS advise you to thoroughly read through the user manual. All the information you need to operate the AR-200 safely and securely can be found here.

1.1. Purpose

The AR-200 is a Ceiling Hoist intended for passively moving care recipients. The care recipient can be lifted with the help of the Ceiling Hoist and then moved by means of a track on the ceiling.

The Ceiling Hoist can be equipped with a 2-point Spreader Bar, a 4-point Spreader Bar, mechanical 4-point Spreader Bar or an electrically adjustable 4-point Spreader Bar, which is used to move the care recipient. The Spreader Bar must be used in combination with appropriate slings. The moving of a care recipient is also referred to as a 'transfer'.

Some examples of transfers for which the Ceiling Hoist can be used are:

- From a chair or wheelchair to a bed and vice-versa.
- From a chair or wheelchair to a toilet and vice-versa.
- From a chair or wheelchair to a shower-bath-toilet chair or stretcher and vice-versa.
- From a chair or wheelchair into a bath/swimming pool and vice-versa.
- From the floor to a chair, wheelchair or bed.

The care recipient is lifted from a seated or lying position. The transfer must be performed in a semi-seated or seated position. After moving the Ceiling Hoist, the care recipient can be returned to a seated or lying position. This depends on the type of Spreader Bar that you use.

1.2. Target audience

The Ceiling Hoist is intended for care professionals who care for people who are unable to move independently or who have limited mobility, the care recipients.

1.3. Symbols used



Warning: possible risk of physical injury.



Remark.

An explanatory overview of the symbols and the label used on the Ceiling Hoist can be found in the appendix (*section 8*).

1.4. Safety



The Ceiling Hoist is only suitable for moving care recipients. Products and/or any other objects may not be moved with the Ceiling Hoist!



It is not permitted to use the Ceiling Hoist to lift a weight exceeding 200 kg.



It is not permitted to use the Ceiling Hoist to lift a care recipient who exceeds the margins with regards to dimensions of the accessories.



PLS and your distributor cannot be held responsible for any damage caused by accidental, inappropriate, improper, incorrect or injudicious use (described above) or by insufficiently qualified persons. In case of doubt, please contact your distributor.

1.5. Package contents

Remove the packaging and check the contents. The package contains the following:

- One AR-200 Ceiling Hoist (1).
- One Hand Control (2)
- Documentation, consisting of:
 - This user manual.
 - The Basic Instructions Card for the AR-200.

*A short description of the most important functions.
Not an adequate replacement for the user manual!*

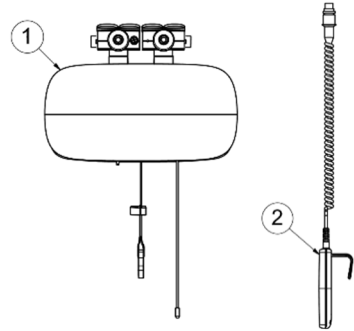

Figure 1, package contents

A wall charger consists of a Hand Control holder and a charger that is mounted on the wall (*section 2.2*).

Wall chargers are separate items and are not included in the package contents.

Please contact your distributor if parts are missing.

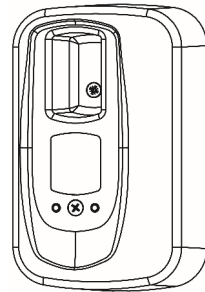

Figure 2, wall chargers

1.6. Setting up

The Ceiling Hoist and wall charger(s) are installed by your distributor and are ready for use.



Please contact your distributor if the installation has not been carried out according to your requirements.

1.7. Correct and incorrect use

- The Ceiling Hoist is suitable for use with wheelchairs and does not require footplates/leg supports or armrests to be removed.
- The Ceiling Hoist is suitable for use with a bed, shower frame or dressing table at working height.
- The Ceiling Hoist is suitable for transfers from and to the floor.

The conditions for the safe transfer of a care recipient are described in *section 4*.

1.8. Cautions and warnings

- It is not permitted to use the Ceiling Hoist to lift a weight exceeding 200 kg*!
- This Ceiling Hoist has been designed to lift and move care recipients in combination with an appropriate sling and should only be used for this purpose! No other uses are permitted!
- Carefully attach the sling clips or loops to all the hooks of the Spreader Bar of the Ceiling Hoist, so that the loops or clips do not fall out of the hooks. If this is not done properly, the care recipient risks falling from the Ceiling Hoist and suffering serious injuries!
- When lifting, you should always check that there is sufficient space above the care recipient!
- Do not raise the care recipient higher than is necessary for the transfer!
- Handle the Ceiling Hoist with care and ensure that the work area is clean and tidy!
- Avoid impacting the end stops at full speed!
- Never move the Ceiling Hoist faster than walking pace along the rail system!
- Move the Ceiling Hoist smoothly to avoid swinging the care recipient unnecessarily!
- Never leave a care recipient unattended while suspended from the Ceiling Hoist!

- Only use the Ceiling Hoist with an approved sling that carries a legible CE label!
 - The Ceiling Hoist may only be operated by suitably qualified care providers who have received instructions from the distributor!
 - The Ceiling Hoist must undergo a periodic inspection at least once every year by a technician employed by the distributor.
 - The Ceiling Hoist may only be serviced and maintained by suitably qualified technicians!
 - Use only original parts provided by PLS for repairs and replacements!
 - Structural parts of the Ceiling Hoist may only be replaced by suitably qualified technicians!
 - Batteries should always be charged in a well-ventilated and dry area!
 - Chargers should be connected in accordance with the applicable installation instructions!
 - Chargers must be inspected at least once per year!
 - The Ceiling Hoist must not be used if it has been deformed due to incorrect use or during transport. Return the Ceiling Hoist to the supplier!
- * The maximum lift capacity of the Ceiling Hoist is 200 kg. The slings and the rail may have other maximum payloads.

2. Functional overview and description

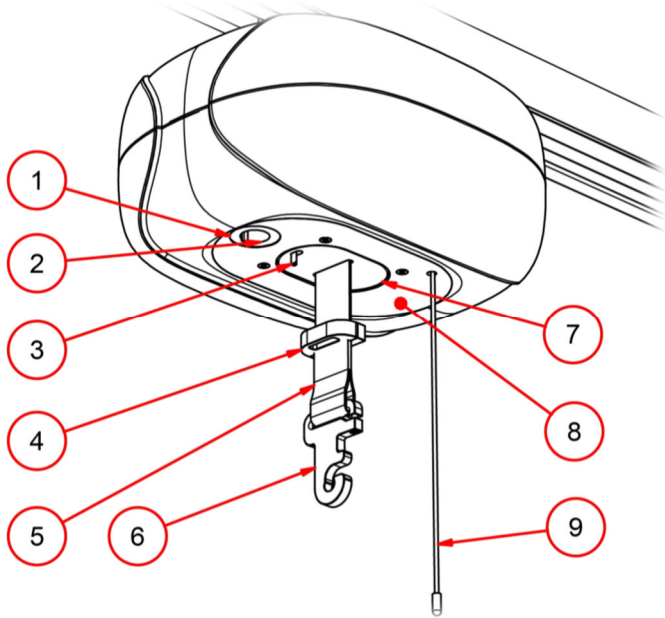

Figure 3, underside of the AR-200 Ceiling Hoist

Number	Explanation	Reference
1	Control lights.	Section 2.3
2	Connection socket for Hand Control.	Section 2.1.2
3	Hand Control latch.	Section 2.1.2
4	Hoisting belt clip for Hand Control.	Section 2.1.3
5	Hoisting belt.	Section 2.4.4
6	Central Suspension Point for Spreader Bar.	Section 3.5
7	Height limit switch.	Section 2.4.2
8	Connection socket for electrical 4-point Spreader Bar.	Section 2.5
9	Emergency stop cord.	Section 2.4.3

The parts are dealt with in the specified sections.

2.1. Operation

The Hand Control has two functions: namely both the control and charging of the Ceiling Hoist.

2.1.1. Functional overview buttons

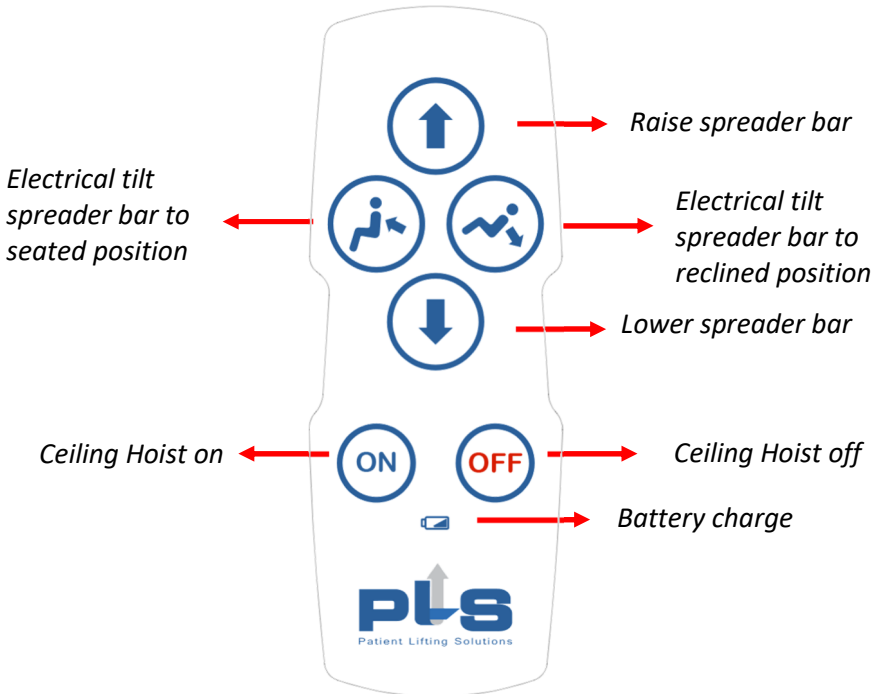
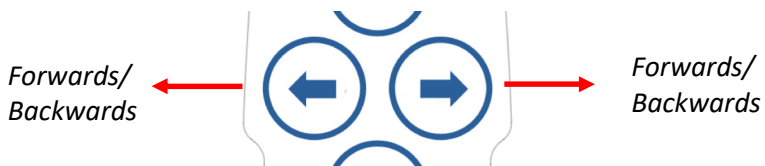

Figure 4, PLS handset buttons



Before the lowering function starts working, there should be a load hanging on the hoisting belt (see section 2.4.4).

If a Driven Trolley is mounted, the function buttons are as follows;



2.1.2. Connecting the Hand Control

1. Push the Hand Control latch (no. 3) aside.
2. The plug on the Hand Control must be pressed firmly into the socket on the underside of the Ceiling Hoist, while holding the latch aside.
3. Release the latch.
4. Pull gently on the plug to make sure it is locked in position.

The Hand Control is under less stress thanks to the locking system.

This prevents the plug from being pulled out of the Ceiling Hoist.

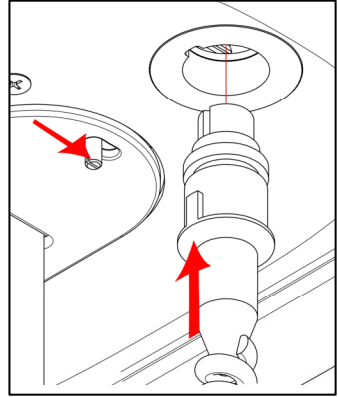



Figure 5, connecting the Hand Control

2.1.3. Placing the Hand Control

When moving a care recipient, the Hand Control can be hung on the hoisting belt clip. When the Ceiling Hoist is not in use, it is recommended to place the Hand Control in the wall charger so that the hoist can charge (see section 2.2).

 Never use the Hand Control or the Spreader Bar cable as a pull cord!

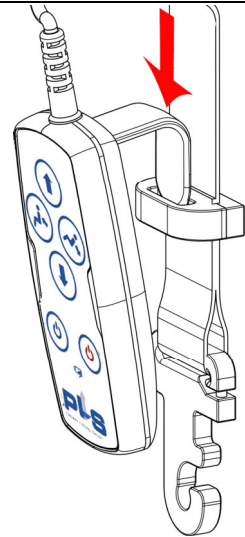

Figure 6, Hand Control in hoisting belt clip

2.2. Charging

To maximise the lifespan of the batteries, it is recommended to charge them whenever the Ceiling Hoist is not in use. Charge the batteries as follows:

1. Place the Hand Control in the wall holder (*Figure 7, page 12*).
2. Check that the green charging light is on.
3. Check that the control light lights up. It will successively flash red, orange and green, depending on the charge level of the battery.

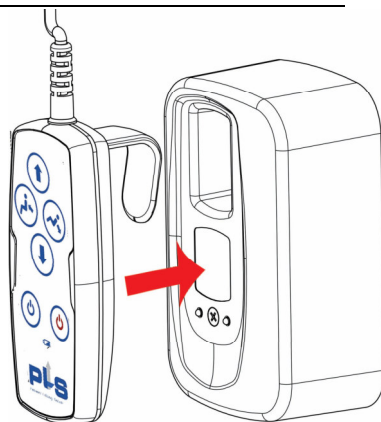

Figure 7, Hand Control in wall charger

If the flashing of the control light is undesirable, for example in a bedroom, you can switch it off using the button '**Ceiling Hoist off**' on the Hand Control. The Ceiling Hoist continues to charge even when turned off.

You can have the bedroom mode programmed as an extra option if desired. The charging indicator will then automatically switch off after 2 minutes. The Ceiling Hoist still continues to charge.



Charge the batteries in a dry area!



You should allow for a charging time of around 8 hours if the batteries have a very low charge!

The number of lift movements that can be made with a fully charged battery depends on the duration of the lift movements, the weight lifted, and the age and condition of the batteries.

2.3. Control lights

On the underside of the Ceiling Hoist, around the connection socket for the Hand Control, you can see a coloured ring (*Figure 3, page 9*). The control lights show the status of the batteries, and whether these are being charged (*flashing, see section 2.2*) when the Hand Control is placed in the wall charger. This ring lights up in one of the following three colours, depending on the status:

2.3.1. Green ring

The green light indicates that the Ceiling Hoist is active. In order to save battery life, the Ceiling Hoist will switch off automatically after 30 minutes of not being used. Press the button '**Ceiling Hoist on**' on the Hand Control to switch the Ceiling Hoist back on.

2.3.2. Orange ring

The orange light indicates that the batteries must be charged as soon as possible. The level is not yet critical, but it is recommended to charge the batteries. Charge the batteries as described in *section 2.2*.

2.3.3. Red ring

The red light indicates that the batteries have reached a critical level. You can no longer use the Ceiling Hoist. Charge the batteries as described in *section 2.2*. If the critical level is reached while moving a care recipient, you can still lower the care recipient (once).

2.4. Safety system

2.4.1. Battery monitoring (light and sound signals)

Because discharging the batteries fully reduces their lifespan considerably and also affects the lift capacity and ease of use, the Ceiling Hoist is equipped with a system to prevent complete discharge.

During the orange status (*section 2.3.2*), when charging is recommended but not yet strictly necessary, the system will emit a beep every 10 seconds to signal that the Ceiling Hoist needs to be charged (as soon as possible).

If this signal is ignored for a long time, then the Ceiling Hoist will go into red status (*section 2.3.3*). The system will now beep every other second. The only function that will still be available is lowering the hoisting belt.



The Ceiling Hoist should now be continuously charged for at least 2 hours before it can be used again.



Batteries that are not used for an extended period of time will gradually lose their charge. Allowing the battery to lose too much charge harms its capacity and lifespan.



The red status is only reached when the orange status has been ignored for a long time. However, if the red status follows the orange status quickly, it is likely that the batteries have reached the end of their lifespan. In this case, contact your distributor.

2.4.2. Height limit switch

The height limit switch or limit stop (*Figure 3, page 9*) ensures that the system switches off when the maximum lift height is reached or if the care recipient is hoisted at a skewed angle. You can still lower the hoisting belt.

2.4.3. Emergency stop

The Ceiling Hoist has a red emergency stop cord (*Figure 8, page 15*). Use this cord in emergency situations. When you pull the cord shortly, the Ceiling Hoist will stop. Continue pulling the cord to lower the Spreader Bar slowly. This will still enable you in all situations to place the care recipient into a wheelchair, for instance.

Release the cord to stop lowering. The Ceiling Hoist will then be switched off fully.

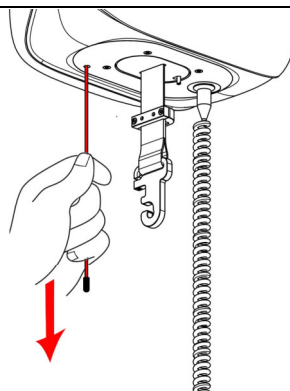

Figure 8, emergency stop

Press the button '**Ceiling Hoist on**' on the Hand Control to switch the Ceiling Hoist back on (*Figure 4, page 10*).

2.4.4. Belt tension

This function prevents the hoisting belt from congesting in the Ceiling Hoist when the belt is lowered without a load. The Ceiling Hoist is activated by a load equivalent to the PLS Spreader Bar, and without a load the Ceiling Hoist is on but the motor will not work. If you want to lower the hoisting belt without a load, you can pull gently on the belt or the Central Suspension Point while also pressing the 'Lower hoisting belt' button.

2.4.5. Belt switch

Turns off the Ceiling Hoist's motor when the hoisting belt is at its end. The hoisting belt can now only be raised.

2.5. Mechanically or electrically adjustable 4-point Spreader Bar

The Ceiling Hoist is available with a 2-point Spreader Bar, or a mechanically or electrically adjustable 4-point Spreader Bar or tilt Spreader Bar. A tilt Spreader Bar enables you to bring the care recipient to a seated or lying position. If you use an electrical 4-point Spreader Bar, this should be connected with a coiled cable into the socket indicated (*no. 8, Figure 3, page 9*). The Spreader Bar can then be operated using the Hand Control.

3. PLS Spreader Bar

The PLS Spreader Bar can be attached to the PLS Central Suspension Point (CSP).

3.1. Safe Working Load table

Type + number	Safe Working Load	Suitable to;
2-point Spreader Bar (8102)	275 kg	AR-200 and AR-275
4-point Spreader Bar (8103)	500 kg	AR-350 and AR-500



Slings may have another Safe Working Load than the Spreader Bar! Please, check this before lifting!



The PLS Spreader Bar may only be modified, to be added to the hole version of the CSP, by your distributor!



PLS and your distributor cannot be held responsible for any damage caused by accidental, inappropriate, improper, incorrect or injudicious use (described above and in section 1.4) of the PLS Spreader Bar or by insufficiently qualified persons. This also applies the use of a Spreader Bar or Sling made by any other company than PLS. In case of doubt, please contact your distributor.

3.2. Important

Plan the movement of the care recipient. Avoid situations in which the care recipient is in the sling without supervision. Before lifting, check that the care recipient is completely free of his / her environment so that body parts do not get trapped. Be careful with hoses and / or wires that are attached to the user. The user is not allowed to hold the carrying strap during movement because there is a chance that the

loops will shift during lifting. This could cause constriction. Before lifting, make sure that the hand control and the cable are free of the Spreader Bar, the care recipient and any other object.

3.3. Explanatory label overview

2-Point Spreader Bar example:

- 2021-01 = Year – Month. Also, the batch number.
- 8102 = type number of the Spreader Bar, in this case a 2-Point Spreader Bar.
- SWL = Safe Working Load in kilogram.
- Manufacturer's name and address data.

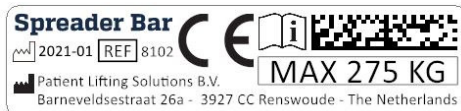

3.4. Connect and release

The blue dot has a marking function. Only when the slot is in the same line as the dot, the hook can be connected and released on/off the Spreader Bar.

1. Hold the hook 90° to the Spreader Bar.
2. Place the opening of the hook over the pen of the Spreader Bar.
3. Pull back the hook and in the same movement, turn it back.

4. Please, reverse these steps to release the Spreader Bar.

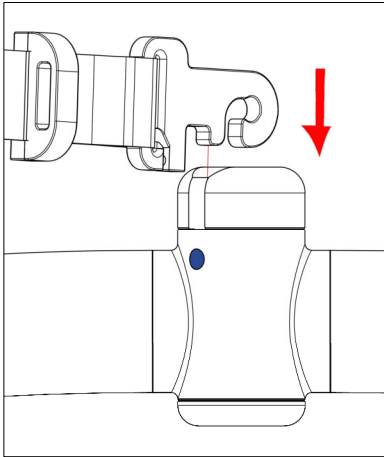

Figure 9, step 1 and 2

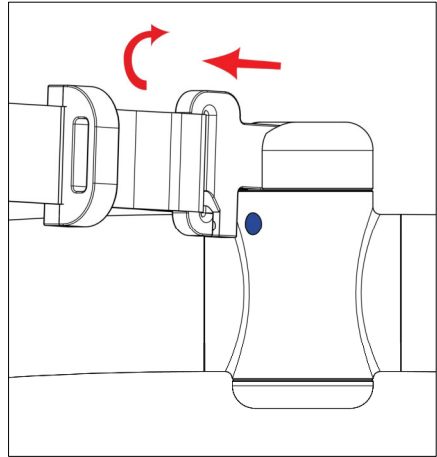

Figure 10, step 3

3.5. Attaching the Sling



Be careful when attaching the lifting slings loops in/on the hooks! Use **all the available** hooks to attach the sling!



Please make sure that the loops of the sling are secured in **all available** (2 or 4 hooks) hooks of the Spreader Bar!



Stay alert when lifting is started. The loops must stay in place!



Figure 11, attaching the loops of the Sling on all the available hooks

4. Lifting a care recipient

Follow the steps below to lift a care recipient safely:

1. Before using the Ceiling Hoist, always inspect the devices you will be using.
2. Secure the sling according to the instructions provided by the supplier of the sling.
3. Secure the sling to the Spreader Bar with loops or clips.
4. Use the Hand Control to lift the care recipient. The ideal lifting height is when there is good eye contact between the care recipient and the carer (eye level).
5. Walk alongside the Ceiling Hoist when riding and stay near to the care recipient.
6. Move the Ceiling Hoist to the bed, chair or toilet.
7. Now lift the care recipient to the height required to bring the person to the desired position.
When using an electrically adjustable 4-point Spreader Bar, you can use the Hand Control to bring the care recipient into a seated or lying position.
8. When lowering the care recipient, ensure that the hoisting belt is taut at all times. The Ceiling Hoist will stop if the hoisting belt becomes slack.



Never use the Hand Control or the Spreader Bar cable as a pull Cord. The Spreader Bar can be used as a handle to move the Ceiling Hoist. Always follow behind the care recipient and push the person along the path of the rail to the desired place.



Do not raise the care recipient higher than is necessary for the transfer.



The Ceiling Hoist may only be operated by suitably qualified care providers who have received instructions from the distributor.



Always lift the care recipient with a straight hoisting belt hanging vertically beneath the Ceiling Hoist (*Figure 12*).

This is important:

- with regard to the safety and comfort of the care recipient.
- to avoid wear to the hoisting belt that may occur if it rubs on the height limit switch of the Ceiling Hoist.
- to prevent the height limit switch of the Ceiling Hoist from being activated which means that the Ceiling Hoist can only be lowered.

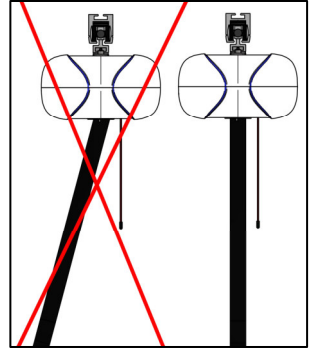

Figure 12, correct and incorrect position of the hoisting belt

5. Detachable version

The AR-200 is also available as a detachable version (AR-200D). The Ceiling Hoist is then fitted with a detachable trolley. The Ceiling Hoist can easily be detached from the trolley by lifting it up about 15 mm and turning it 90 degrees. In order to put the Ceiling Hoist back onto the trolley, push the Ceiling Hoist onto the trolley at a 90-degree angle from the rail. Push the Ceiling Hoist as far as possible onto the trolley and turn it 90 degrees. The Ceiling Hoist should now be attached to the trolley again. For extra safety, the Ceiling Hoist will not work if it is not correctly attached to the trolley.



Figure 13, detaching of the Ceiling Hoist

6. PLS Rail System (optional)

The rail system that you have chosen can be fitted with a Transit Coupling, Turntable or Track-Switch.

6.1. Turntable

A turntable allows you to traverse crossings in the rail system.

If you leave the Ceiling Hoist in the middle of the turntable for 1.5 seconds, the status lighting will turn green and it will automatically make a quarter turn. You can leave the turntable at both sides.

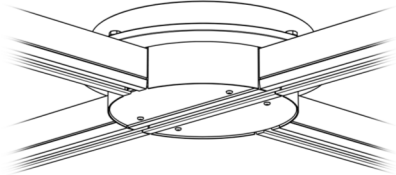

Figure 14, Turntable

If you use multiple Ceiling Hoists in your system, it is possible that you will not be able to ride straight into a turntable because it is turned. Wait for 1.5 seconds at a safe distance from the turntable, after which the turntable will make a quarter turn, allowing you to ride into it.

6.2. Track-Switch

You can use a Track-Switch to create a junction in a continuous rail.

If the Track-Switch is in the correct position, you can continue moving.

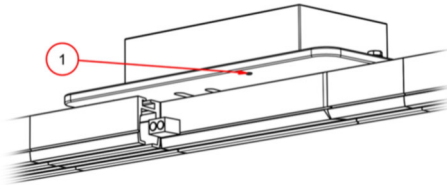

Figure 15, Track-Switch

If this is not the case, then stop moving the Ceiling Hoist for 1.5 seconds at a safe distance from the Track-Switch. The status light (1) will turn green and the switch will automatically change direction. You can continue the transfer.

6.3. Transit Coupling

If your rail system is fitted with an XY system, you can connect the movable rail to the rest of the track. You do this with a Transit Coupling (*Figure 16 , page 25*).

1. Slide the movable rail level with the fixed rail.
2. Gently move the Ceiling Hoist towards the Transit Coupling until the status light (1) turns red.
3. After 1 second, the Transit Coupling will automatically make the connection between the movable and fixed rails.
4. Upon connection, the status light (1) will turn green.
5. You can now safely move the Ceiling Hoist off the movable rail.

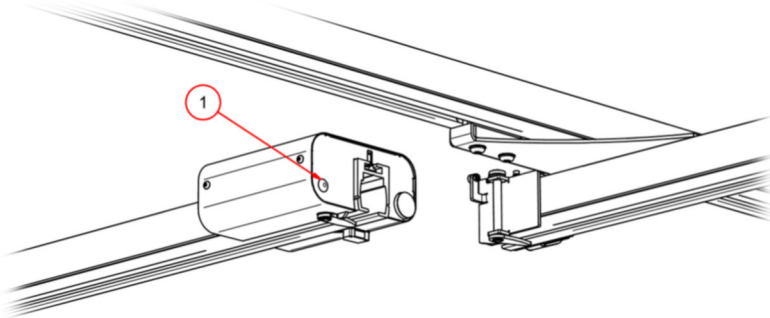

Figure 16 , Transit Coupling

When you want to move the Ceiling Hoist from the fixed rail back to the movable rail, the Transit Coupling will automatically uncouple so that you can use the XY system again.



Keep a safe distance during turn, switch and Transit Coupling events. This way, moving parts are protected. The distance depends on the distributor's settings.



Only move the movable rail when the Ceiling Hoist is in the movable rail.



There may never be more than one Ceiling Hoist on an XY system at any one time.

7. Maintenance

The Ceiling Hoist meets the requirements and specifications of the applicable European directives, regulations and amendments.

7.1. Lifespan

The expected lifespan of the Ceiling Hoist under normal use and normal circumstances when maintained in accordance with the instructions is 10 years (~15000 transfers). Hoisting belts, slings and batteries are not included in this.

Special circumstances such as use in a humid environment or in an environment where corrosive vapours are present may reduce the lifespan of the Ceiling Hoist.

7.2. Schedule

The Ceiling Hoist has been designed to require minimum maintenance. The following maintenance schedule is recommended:

- Daily and weekly maintenance must be done by Ceiling Hoist users.
- The annual inspection and any repairs to the Ceiling Hoist must be performed by the distributor or by specially trained technicians.

Contact the distributor for details about maintenance contracts.



If you have any doubts about the condition of the Ceiling Hoist, always contact your technical department or the distributor.

7.3. Daily maintenance

Daily maintenance consists of the following actions:

- Checking whether all parts of the Ceiling Hoist are present.
- Checking the devices (lifting slings) used for loose stitching or loose parts before each use.
- Checking the Spreader Bar's connection to the Central Suspension Point. This must not be loose.
- Regularly checking the status of the hoisting belt.

7.4. Weekly maintenance

Weekly maintenance consists of the following actions:

- Checking the operation of the emergency stop and the height limit switch (*see sections 2.4.2 and 2.4.3*).
- Check whether all moving parts can move freely without any annoying noises.
- Check that the user manual, basic instruction card and log book are present.



If you have any doubts about the condition or correct operation of the Ceiling Hoist, always contact the technical department or the distributor.

7.5. Annual inspection and maintenance

The Ceiling Hoist must be inspected once a year in accordance with the NEN-EN-ISO 10535 standard. The chargers should also be inspected every year in accordance with the applicable requirements. These inspections should be carried out by the distributor or by another suitably authorised body.

The distributor offers you the option of having your Ceiling Hoist thoroughly inspected once a year under a maintenance contract. Contact the distributor for more details about this.

7.6. Removing parts

Any parts that are replaced or removed can be returned to the distributor. You can also give these parts to the technician for destruction. PLS or the distributor will ensure that these parts are processed in an environmentally friendly manner.



If you dispose of parts yourself, the batteries must be disposed of as chemical waste and the electronic components must be processed according to the WEEE guideline.



7.7. If the Ceiling Hoist is not working

Check the following if the Ceiling Hoist is not working:

- Check whether the batteries are sufficiently charged. The control lighting shows the status of the batteries (*see section 2.3*). When they are empty, charge them according to the instructions in *section 2.2*.
- Verify that the emergency stop has not been activated. For problem recognition and resolution, *see section 2.4.3*.
- Verify that the height limit switch has been pushed in (*see section 2.4.2*). It is still possible to lower the Spreader Bar.
- Check whether the belt is slack and pull it tight if necessary (*see section 2.1.1*).
- Check whether the plug of the Hand Control is properly connected. If not; remedy this according to *section 2.1.2*.

If you continue to experience problems, contact the technical department or the distributor.

8. Appendix

8.1. Warranty Provisions

PLS provides a 5-year warranty for the AR-200. PLS does not offer any guarantee on components that are prone to wear and tear, such as wheels, hoisting belts, slings and batteries.

The guarantee does not cover damage or defects that may be caused to the AR-200 Ceiling Hoist due to incorrect or imprudent use and repairs by people who are not suitably qualified. PLS or the distributor will evaluate this.

PLS retains the right to make adjustments to the product which deviate from the descriptions in this user manual. It will not be responsible for this.

Should changes be made that affect the function, operation or form, resulting in the inability of the user to operate the Ceiling Hoist without instruction, PLS will provide updated documentation. The distributor is responsible for supplying users with this information.

8.2. About Patient Lifting Solutions

Patient Lifting Solutions (PLS) designs, develops and manufactures Ceiling Hoist solutions for the healthcare sector. We can conceive a reliable lifting system for any ceiling and in any situation.

PLS aims to provide a ceiling lift system that is user-friendly and possesses advanced technology.







The products are designed and made by PLS in The Netherlands and distributed by local distributors.

8.3. Contact details Patient Lifting Solutions

Patient Lifting Solutions B.V.
Barneveldsestraat 26a
3927 CC Renswoude
The Netherlands
Email: info@plsbv.com
Web: www.plsbv.com



8.4. Explanatory label overview

Symbol	Explanation
	The product manufacturer.
	The date of the product's manufacture.
	Read the User Manual before operating the Ceiling Hoist.
	Serial number of the product
	WEEE (Waste of Electrical and Electronic Equipment)
	CE-marking.
	Website symbol.

The label can be found on top of the Ceiling Hoist. Information on the label:

- Type of the relevant product.
- Maximum permitted lifting weight.
- Serial number (example 1810-10036) consisting of:
 - 20: year of manufacture.
 - 11: month of manufacture.
 - 1: version of the product.
 - 0036: number of the product; in this case the 36th Ceiling Hoist produced.
- Manufacturer's name address data and website.
- Manufacturer's logo.
- UDI (GS1 Data matrix) consisting of;
 - GTIN (Product identification): 08720165793006
 - Serial number, in this case; 2011-10036



Figure 17, overview of the label

8.5. Technical specifications

Functions	Value/unit
Maximum lifting capacity	200 kg
Operation	Hand Control
Minimum charging time (critical level)	8 hours
Switch-off time when not in use	30 minutes
Switch-off time charge indication (bedroom mode)	2 minutes
Number of lifts per charge @70 cm	>70 @80 kg >40 @120 kg

Dimensions (Figure 18)	Value/unit
Length (A)	270 mm
Width (B)	307 mm
Height (C)	148 mm
Minimum hoisting belt length (D)	136 mm
Maximum hoisting belt length (E)	2260 mm

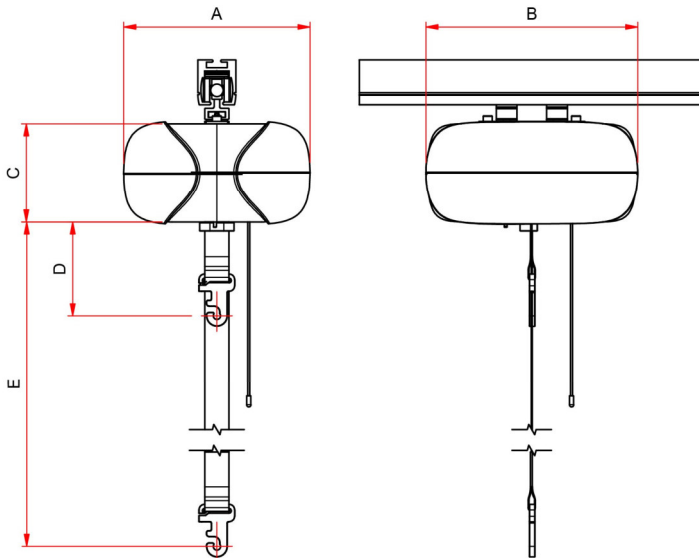

Figure 18, Ceiling Hoist dimensions

8.6. EC Declaration of conformity

1) We,



Patient Lifting Solutions (PLS) BV
Barneveldsestraat 26a
3927 CC Renswoude
The Netherlands



2) Accept full responsibility that the devices in the product groups:

- **PLS Ceiling Hoist**
- **PLS Rail System**
- **PLS Accessories**

Contact PLS for the list of devices.

3) Conform with the following standards:

- Regulation (EU) 2017/745

4) Supplementary information:

Issued at:
Renswoude, the Netherlands

Date of issue:
26 May 2021

M. van den Brandt
Managing Director

